

+ FRAME & HEADER KITS

EVOMAX

30 - 150

30P - 80P

When replacing any part on this appliance, use only spare parts that you can be assured conform to the safety and performance specification that we require. Do not use reconditioned or copy parts that have not been clearly authorised by Ideal.

For the very latest copy of literature for specification and maintenance practices visit our website www.idealcommercialboilers.com where you can download the relevant information in PDF format.

This kit is suitable for the following boilers:

Evomax 30, 40, 60, 80, 100, 120, 150, 30P, 40P, 60P 80P

CONTENTS

1 Introduction.....	3
2 General Description of Cascade Systems	3
3 Multiple Boiler System Components	5
4 Installation Drawings for Multiple Boiler Systems	8
Side by Side Frame Kit Configuration	8
Back to Back Frame Kit Configuration	13
5 Wall Mounted Installation Procedure	18
6 Frame Kit Installation Procedure	20
7 Header Kit Assembly.....	21
8 Electrical Connections.....	24
9 Commissioning and Testing.....	24

1 INTRODUCTION

This technical data contains information for dimensioning & assembly of a cascade system kit for the Evomax range of products.

Header and Frame kits are available in both 'in line' (6 boilers long) and back to back options (3 boilers long).

GENERAL DESCRIPTION OF FRAME & HEADER KITS

A requirement to spread the total required heat output over several boilers can be accommodated by the use of the Evomax multiple boiler frame & header kit options.

A sequencer kit can be specified to switch boilers in cascade on or off dependent on total heat demand.

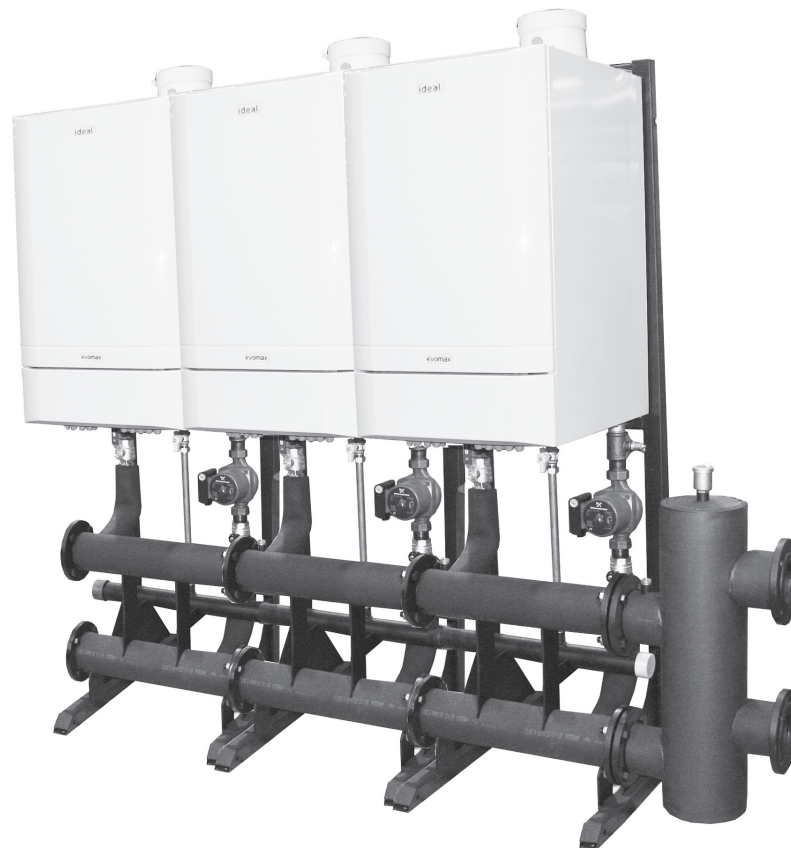

2 GENERAL DESCRIPTION OF CASCADE SYSTEMS

2.1 FRAME AND HEADER KIT DESIGN OPTIONS

The Evomax boilers are suitable for use in a multiple boiler configuration. The Evomax multiple boiler system is available in both side by side and back to back options giving the opportunity to choose the optimum footprint size or wall space for a given output. The table overleaf states options available and gives the minimum number of appliances required, the appropriate floor space & the kit product number (N.B. The kits do not include the boilers).

Side by side kits do not include the support frame as the boilers can be wall mounted but a frame kit is available if wall space etc. does not facilitate boiler/header wall mounting.

continued

FRAME AND HEADER KIT SYSTEM DESIGN OPTIONS

Total Output Required Kw	Side By Side Option – Number Of Boilers/Output Required	Side by Side Footprint Size W x D (mm)	Header Kit Product No. Side By Side	Back To Back Option – Number Of Boilers/Output Required	Back to Back Footprint Size W x D (mm)	Frame/Header Product No. Back To Back
60	2/30	1480x552	209799	2/30	930x950	209901
70	2/30&40	1480x552	209799	2/30&40	930x950	209901
80	2/40	1480x552	209799	2/40	930x950	209901
90	2/30&60	1480x552	209799	2/30&60	930x950	209901
100	2/40&60	1480x552	209799	2/40&60	930x950	209901
110	2/30&80	1480x552	209799	2/30&80	930x950	209901
120	2/60	1480x552	209799	2/60	930x950	209901
130	3/30,40&60	2030x552	209801	3/30,40&60	1480x950	209903
140	2/60&80	1480x552	209799	2/60&80	930x950	209901
150	3/30,40&80	2030x552	209801	3/30,40&80	1480x950	209903
160	2/80	1480x552	209799	2/80	930x950	209901
170	3/30,60&80	2030x552	209801	3/30,60&80	1480x950	209903
180	2/80&100	1480x573	209799	2/80&100	930x1096	209901
190	3/30,60&100	2030x573	209801	3/30,60&100	1480x1096	209903
200	2/100	1480x573	209799	2/100	930x1096	209901
210	4/30,40,60&80	2580x552	209803	4/30,40,60&80	1480x950	209905
220	3/60,60&100	2030x573	209801	3/60,60&100	1480x1096	209903
230	4/30,40,60&100	2580x573	209803	4/30,40,60&100	1480x1096	209905
240	2/120	1480x663	209798	2/120	930x1276	209900
250	4/30,60,80&80	2580x552	209803	4/30,60,80&80	1480x950	209905
260	3/60,100&100	2030x573	209801	3/60,100&100	1480x1096	209903
270	2/120&150	1480x663	209798	2/120&150	930x1276	209900
280	3/80,100&100	2030x573	209801	3/80,100&100	1480x1096	209903
290	4/30,60,100&100	2580x573	209803	4/30,60,100&100	1480x1096	209905
300	2/150	1480x663	209798	2/150	930x1276	209900
310	4/30,80,100&100	2580x573	209803	4/30,80,100&100	1480x1096	209905
320	4/40,80,100&100	2580x573	209803	4/40,80,100&100	1480x1096	209905
330	4/30,100,100&100	2580x573	209803	4/30,100,100&100	1480x1096	209905
340	4/60,80,100&100	2580x573	209803	4/60,80,100&100	1480x1096	209905
350	5/30,40,80,100&100	3130x573	209805	5/30,40,80,100&100	2030x1096	209907
360	3/120	2030x663	209800	3/120	1480x1276	209902
370	5/30,40,100,100&100	3130x573	209805	5/30,40,100,100&100	2030x1096	209907
380	4/80,100, 100 &100	2580x573	209803	4/80,100, 100 &100	1480x1096	209905
390	3/120,120&150	2030x663	209800	3/120,120&150	1480x1276	209902
400	4/100	2580x573	209803	4/100	1480x1096	209905
410	5/30,80,100,100&100	3130x573	209805	5/30,80,100,100&100	2030x1096	209907
420	3/120,150&150	2030x663	209800	3/120,150&150	1480x1276	209902
430	5/30,100,100, 100 &100	3130x573	209805	4/30,100,100&100	2030x1096	209907
440	5/40,100,100, 100 &100	3130x573	209805	4/40,100,100,100&100	2030x1096	209907
450	3/150	2030x663	209800	3/150	1480x1276	209902
460	5/60,100,100,100&100	3130x573	209805	5/60,100,100,100&100	2030x1096	209907
470	6/30,40,100,100,100&100	3680x573	209806	6/30,40,100,100,100&100	2030x1096	209908
480	4/120	2580x663	209802	4/120	1480x1276	209904
490	6/30,60,100,100,100&100	3680x573	209806	6/30,60,100,100,100&100	2030x1096	209908
500	5/100	3130x573	209805	5/100	2030x1096	209907
510	4/120,120,120&150	2580x663	209802	4/120,120,120&150	1480x1276	209904
520	6/40,80,100,100,100 &100	3680x573	209806	6/40,80,100,100,100&100	2030x1096	209908
530	6/30,100,100,100,100 &100	3680x573	209806	6/30,100,100,100,100&100	2030x1096	209908
540	4/120,120,150&150	2580x663	209802	4/120,120,150&150	1480x1276	209904
550	N/A	N/A	N/A	N/A	N/A	N/A
560	6/60,100,100,100,100&100	3680x573	209806	6/60,100,100,100,100&100	2030x1096	209908
570	4/120,150,150&150	2580x663	209802	4/120,150,150&150	1480x1276	209904
580	6/80,100,100,100,100&100	3680x573	209806	6/80,100,100,100,100&100	2030x1096	209908
590	N/A	N/A	N/A	N/A	N/A	N/A
600	4/150	2580x663	209802	4/150	1480x1276	209904
600	5/120	3130x663	209804			
	In line frame kit		206970			
	Mixing header kit DN80		206972			
	Mixing header kit DN100		206973			
	Pump kit (30-100kW)		210362			
	Pump kit (120-150kW)		210363			

2.2 MULTIPLE BOILER INSTALLATIONS

For installing 2 to 6 boilers, the product range includes water and gas headers capable of assembly using threaded socket, compression and flange connections.

2.3 HYDRAULIC ISOLATION: MIXING HEADER (HEADER KITS INCLUDE A LOW LOSS MIXING HEADER)

Creating hydraulic isolation between the boiler circuit and the system circuit is beneficial, this is provided by using a low loss mixing header. This allows a widely varying volume flow on the system side to hardly influence the volume flow on the boiler side. Conversely a widely varying volume flow on the boiler side hardly influences the volume flow on the system side.

2.4 OUTPUT CONTROL

A sequencer kit is available to maximise the efficiency of a multiple boiler installation. Instructions for installation and use are contained in the sequencer kit. The sequencer kit facilitates control of up to five boilers in cascade.

2.5 GAS SUPPLY

The 30,40,60 & 80kW boilers are suitable for use with both natural gas and Propane, category I12H3P. The 100, 120 & 150kW boilers are only available for natural gas, category I2H. Connect the boilers to the gas mains in accordance with the applicable regulations. The gas header connection is a 2" female thread. Refer to the boiler Installation & Servicing Instructions for general GAS SUPPLY details.

2.6 ASSEMBLY

The frames and headers must stand on a flat and level floor of suitable load bearing capacity.

2.7 SAFE HANDLING

This boiler may require 2 or more operatives to move it to its installation site, remove it from its packaging base and during movement into its installation location. Manoeuvring the boiler may include the use of a sack truck and involve lifting, pushing and pulling.

Caution should be exercised during these operations.

Operatives should be knowledgeable in handling techniques when performing these tasks and the following precautions should be considered:

- Grip the boiler at the base.
- Be physically capable.
- Use personal protective equipment as appropriate, e.g. gloves, safety footwear.

During all manoeuvres and handling actions, every attempt should be made to ensure the following unless unavoidable and/or the weight is light.

- Keep back straight.
- Avoid twisting at the waist.
- Avoid upper body/top heavy bending.
- Always grip with the palm of the hand.
- Use designated hand holds.
- Keep load as close to the body as possible.
- Always use assistance if required.

3 MULTIPLE BOILER SYSTEM COMPONENTS

3.1 GENERAL

The multiple boiler systems consist of the following components:

- Frame kit. (Optional only with In-line kits)
- Boiler gas header.
- Boiler flow and return headers supported on mounting skid
- Low loss mixing header
- Hardware pack (includes essential connection and valve components including individual boiler shunt pumps)

3.2 MAIN WATER HEADERS

The main water headers consist of: insulated water flow, insulated water return headers custom sized for all boilers. It is possible to extend the system to a maximum of 6 boilers in a linear configuration or 2 x 3 boilers in a back-to-back configuration. In a back-to-back configuration with an odd number of boilers, the unused connections must also be capped off using blanking caps provided.

Each header kit provides water flow and return headers sized either DN80 or DN100 dependent on total maximum combined heating output required.

3.3 GAS HEADER

The Gas header consists of a custom manufactured 2" manifold. This is located in a cradle incorporated within the header mounting skid.

3.4 MIXING HEADER

The mixing headers are insulated and are supplied with an auto air vent and drain point as standard.

3.5 BOILER SHUNT PUMP

Shunt pumps for inclusion within each boiler return leg are provided in the hardware pack.

Wilco Stratos 25/1-8T3 IH are provided for boilers between 30 & 100kW.

Wilco Stratos 30/1-8T3 IH are provided for the 120 & 150kW boilers.

3.6 BOILER CONNECTION KITS

The connection kit is insulated and contains the following components:

1. Boiler return leg complete with isolating valve, pump, non return valve, drain cock and fibre seals.
2. Boiler flow leg complete with isolating valve, pressure relief valve and fibre seals.
3. Header blanking flanges, fasteners and gaskets
4. Mixing header fasteners and gaskets.

LEGEND

1. 1 1/4" X 3/4" X 1 1/4" Tee
2. Close taper nipple
3. Safety relief valve 3 bar
4. Isolation valve
5. 1 1/4" X 1/2" X 1 1/4" Tee
6. Drain plug
7. Pump fitting
8. Non return valve
9. Isolation Valve
10. Pump inc. gaskets
11. Boiler return flexible connection from header
12. Boiler flow flexible connection from header
13. 1 1/4" taper male to 1 1/4" parallel hex adapter
14. 1 1/4" male hex nipple

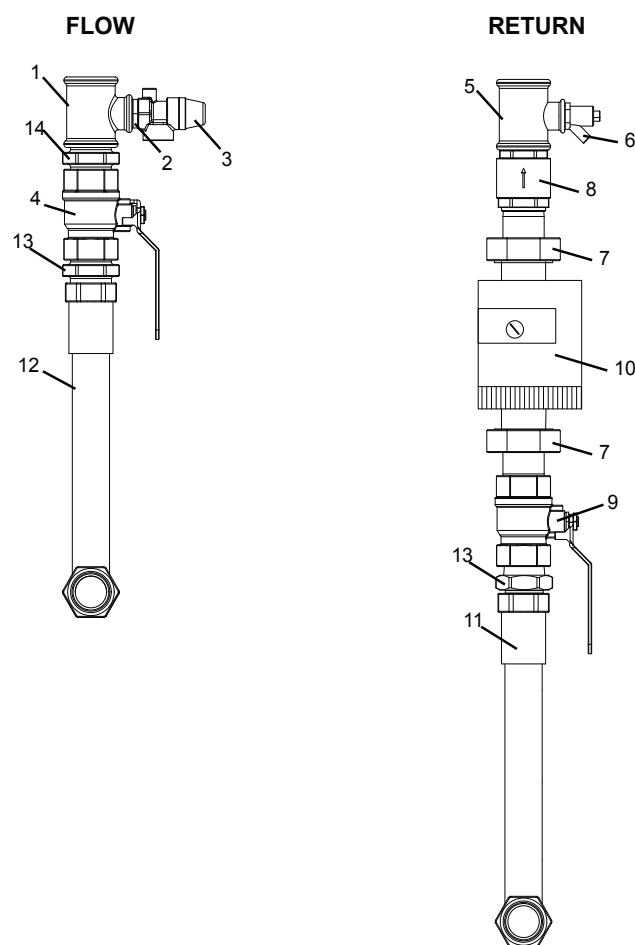

3.7 FREE-STANDING FRAMES

If boilers in cascade are positioned in-line the installer has the option to either wall mount the boilers or mount boilers on optional frame kits available. If mounting in-line product on frames, optional frame kit UIN 206970 must be specified in the correct quantity, one frame kit for each boiler installed in cascade.

If boilers in cascade are positioned back-to-back the correct sized frame mounting kit is supplied as part of the main installation kit.

3.8 INSTALLATION AREA AND DIMENSIONS

Care must be taken to ensure adequate access for boiler / cascade system installation and servicing.

A minimum of 450mm must be provided from the front of the installed boilers in cascade to facilitate boiler servicing.

Consideration to connecting heating flow and return pipework, gas supply and condensate drainage must be given. Routing of the condensate drain must be made to allow a minimum fall of 1 in 20 away from the installed boilers in cascade, throughout its length. Adequate room above the boilers must be provided to install and service the boiler flue system. Further information with respect to flue and condensate drain connection is provided in the installation and servicing instructions provided within the boilers packaging carton.

IMPORTANT POINTS

Before commencing installation:

If Wall mounting;

- Ensure wall is capable of supporting the weight of boilers to be mounted
- Mark drill points of header using floor mounting template
- Mark height on to the wall from the floor to the top of the boiler
- Ensure floor is flat and level and is of suitable load bearing capacity

If Frame mounting;

- The frames must stand on a flat and level floor of suitable load bearing capacity.
- If using a frame kit (UIN 206970) the header must be bolted to the frame before the hoses are connected to the boiler.

These Installations refer to perpendicular wall and floor. If walls are not perpendicular, it is recommended that a frame kit be used (206970). The correct number of frames should be ordered (1 per boiler).

Allowances must be made for installation where skirting boards or other features are in place that may affect the nominal installation conditions.

4 INSTALLATION DRAWINGS FOR MULTIPLE BOILER SYSTEMS

4.1 GENERAL

The multiple boiler systems are available in three formats:

- 2 to 6 boilers in a linear configuration, mounted on a wall.
- 2 to 6 boilers in a linear configuration, mounted on a free-standing frame.
- 2 to 6 boilers in a back-to-back configuration, mounted on a freestanding frame.

The boiler side of the cascade systems is sized to water flow and return differential $20\Delta T$.

4.2 SIDE BY SIDE FRAME KIT CONFIGURATION – FOR BACK TO BACK CONFIGURATIONS - GO TO PAGE 13

4.2.1 INSTALLATION DRAWING WITH 2 – 30-100 BOILERS (SIDE BY SIDE)

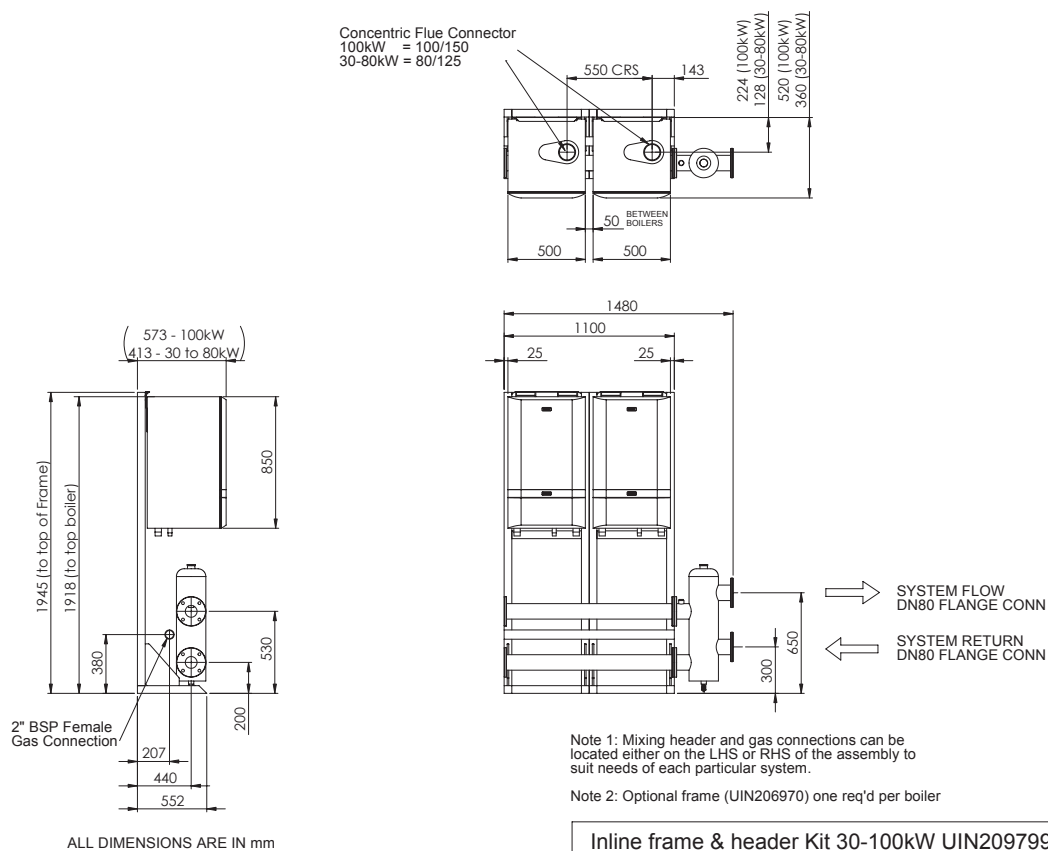

4.2.2 INSTALLATION DRAWING WITH 2 - 120/150 BOILERS (SIDE BY SIDE)

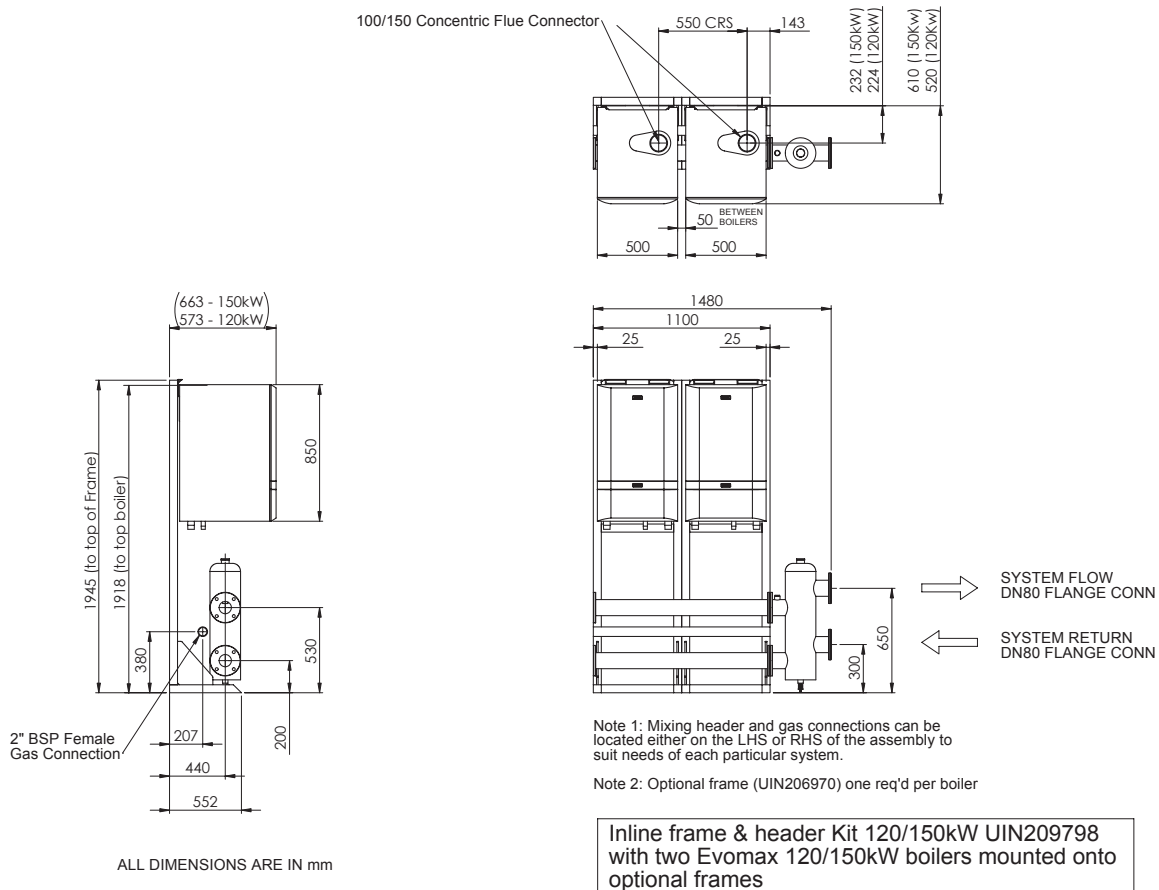

4.2.3 INSTALLATION DRAWING WITH 3 - 30-100 BOILERS (SIDE BY SIDE)

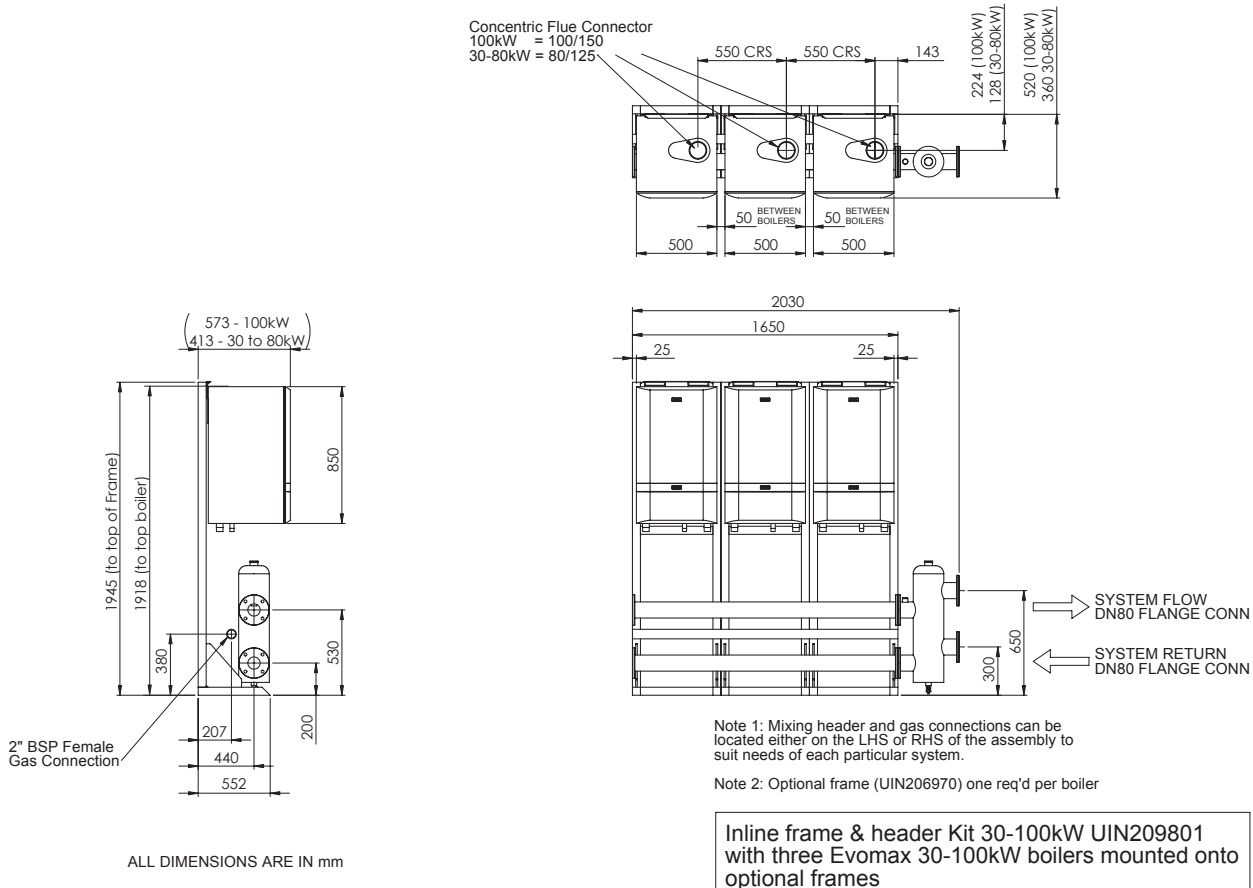

4.2.4 INSTALLATION DRAWING WITH 3 – 120/150 BOILERS (SIDE BY SIDE)

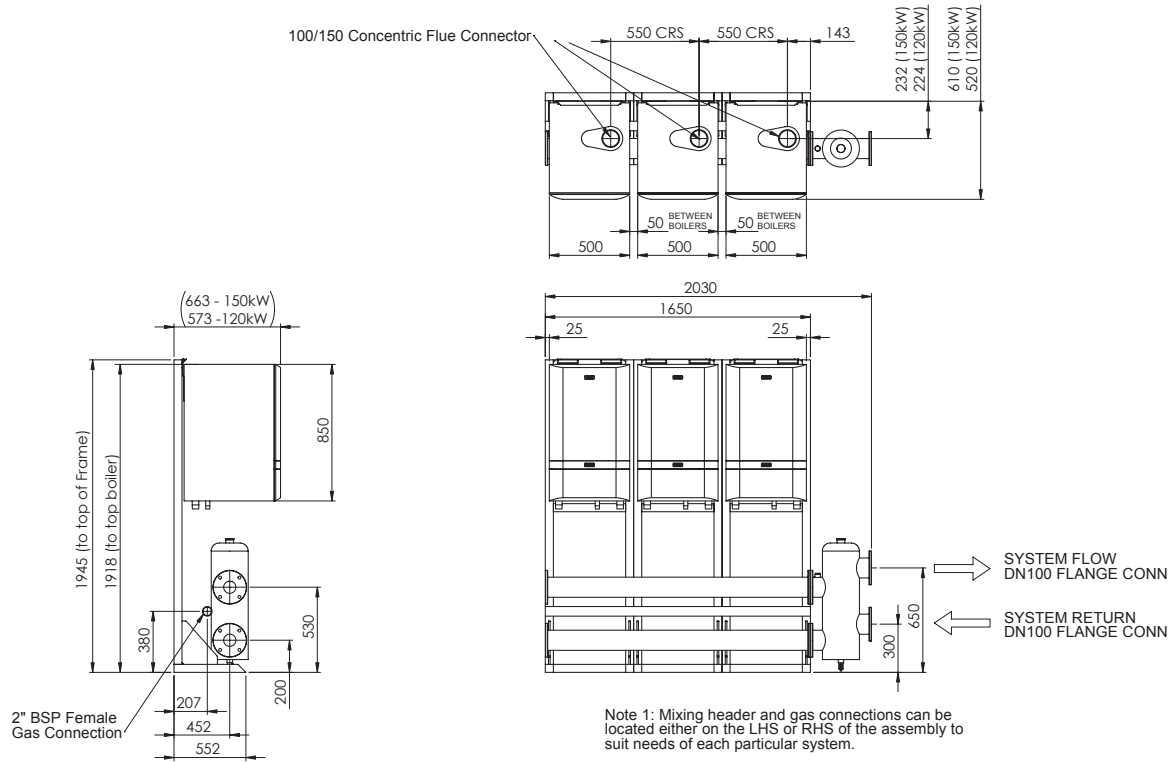

ALL DIMENSIONS ARE IN mm

Inline frame & header Kit 120/150kW UIN209800 with three Evomax 120/150kW boilers mounted onto optional frames

4.2.5 INSTALLATION DRAWING WITH 4 – 30-100 BOILERS (SIDE BY SIDE)

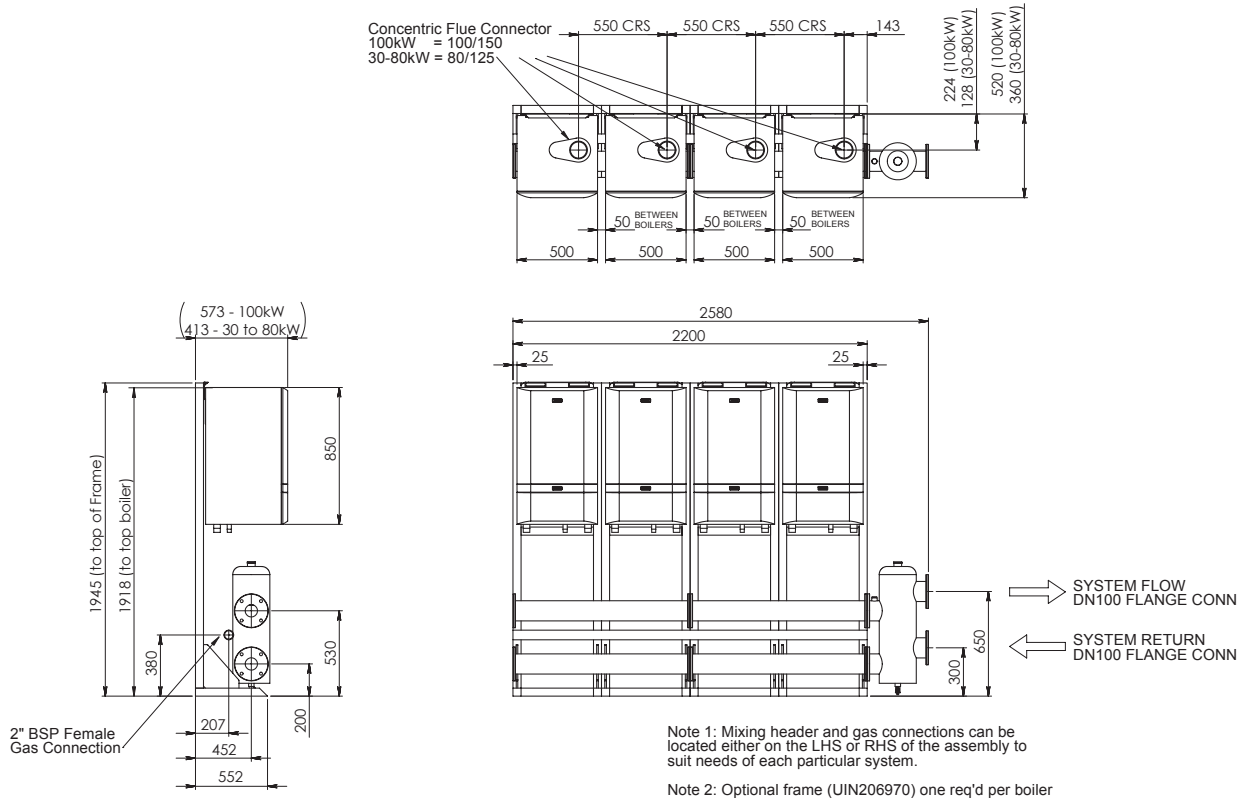

ALL DIMENSIONS ARE IN mm

Inline frame & header Kit 30-100kW UIN209803 with four Evomax 30-100kW boilers mounted onto optional frames

4.2.6 INSTALLATION DRAWING WITH 4 – 120/150 BOILERS (SIDE BY SIDE)

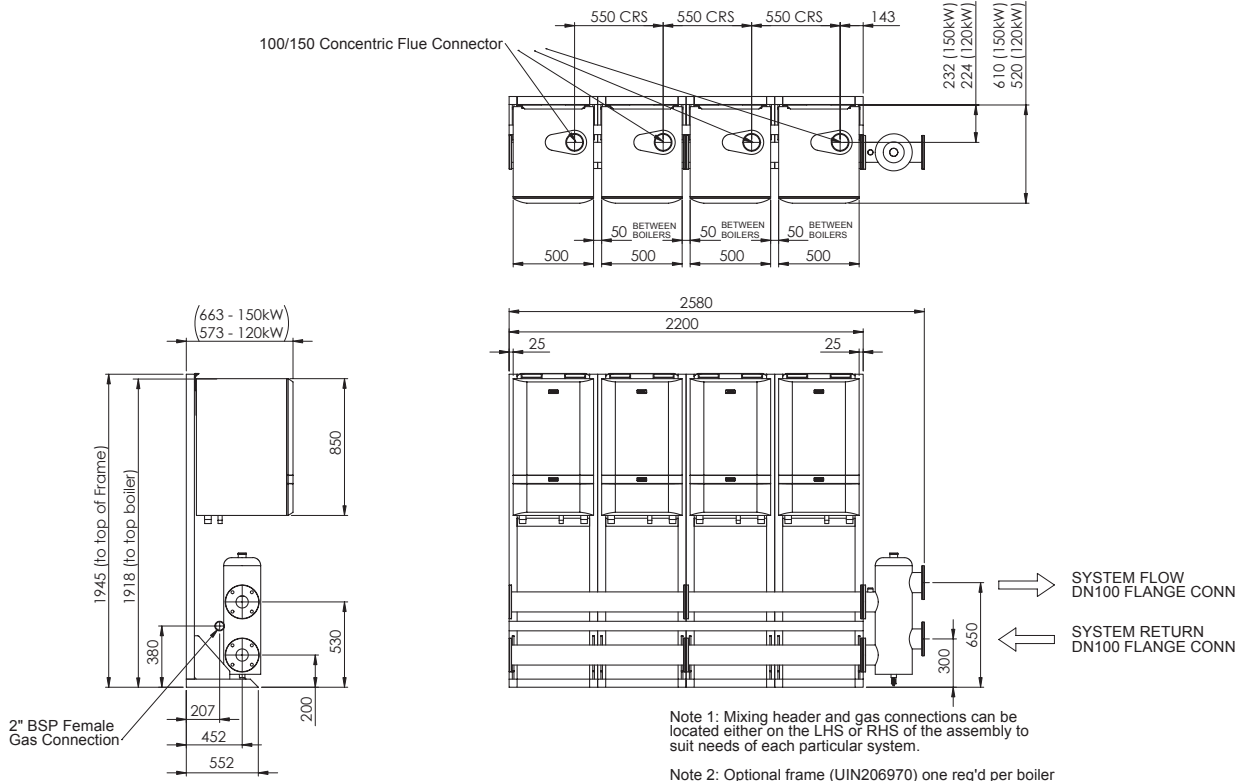

ALL DIMENSIONS ARE IN mm

Inline frame & header Kit 120/150kW UIN209802 with four Evomax 120/150kW boilers mounted onto optional frames

4.2.7 INSTALLATION DRAWING WITH 5 – 30-100 BOILERS (SIDE BY SIDE)

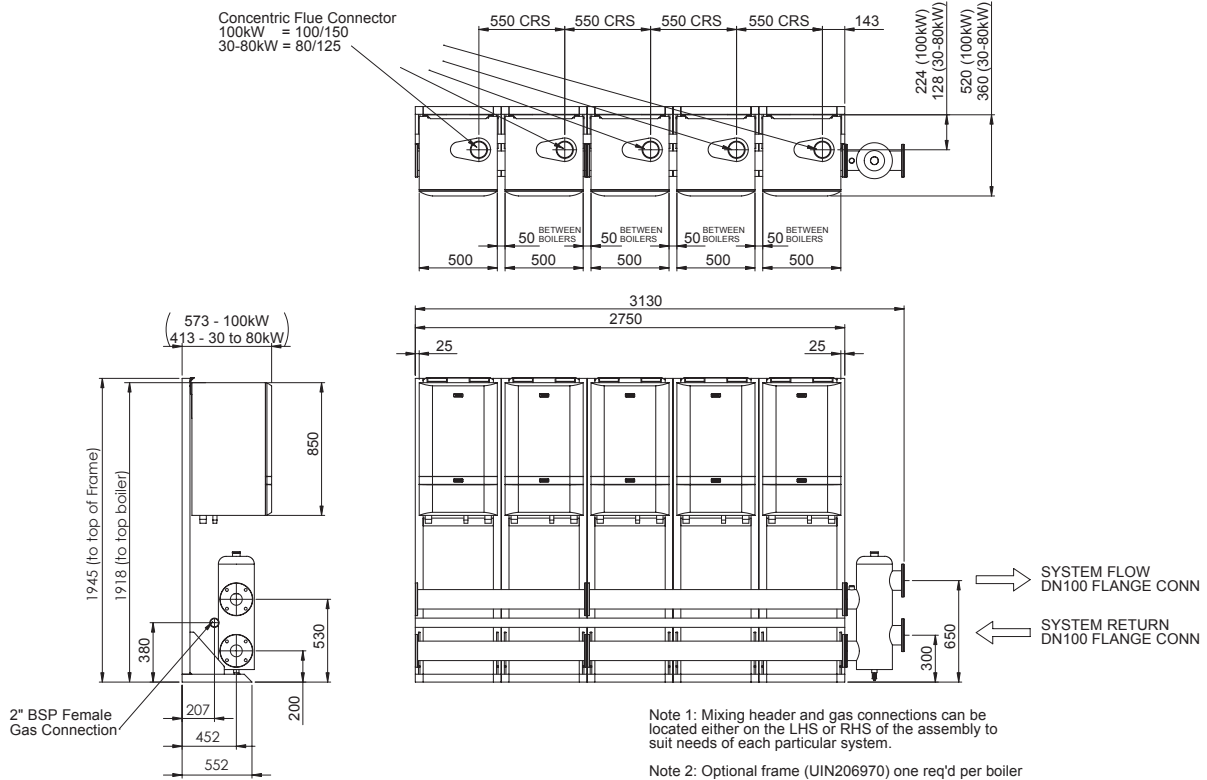

ALL DIMENSIONS ARE IN mm

Inline frame & header Kit 30-100kW UIN209805 with five Evomax 30-100kW boilers mounted onto optional frame

4.2.8 INSTALLATION DRAWING WITH 5 - 120 BOILERS (SIDE BY SIDE)

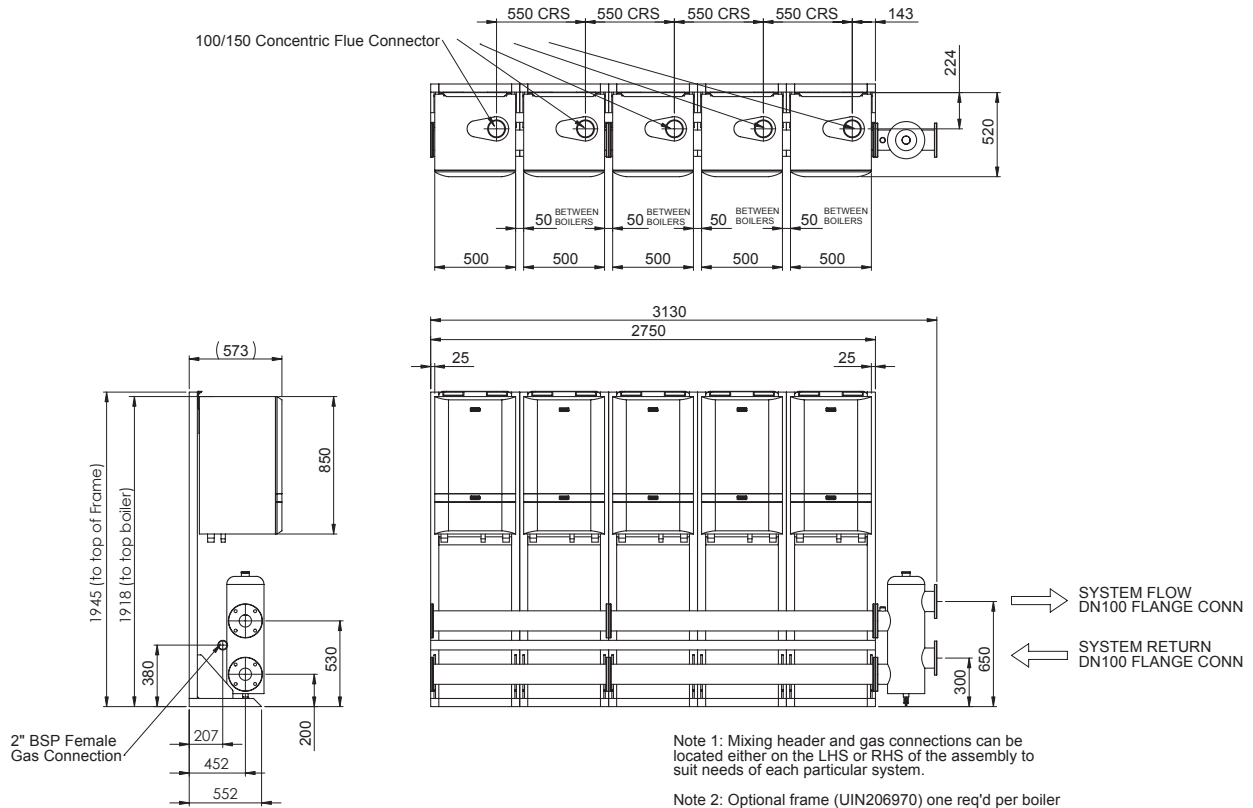

ALL DIMENSIONS ARE IN mm

Inline frame & header Kit 120kW UIN209804 with five Evomax 120kW boilers mounted onto optional frame

4.2.9 INSTALLATION DRAWING WITH 6 - 30-100 BOILERS (SIDE BY SIDE)

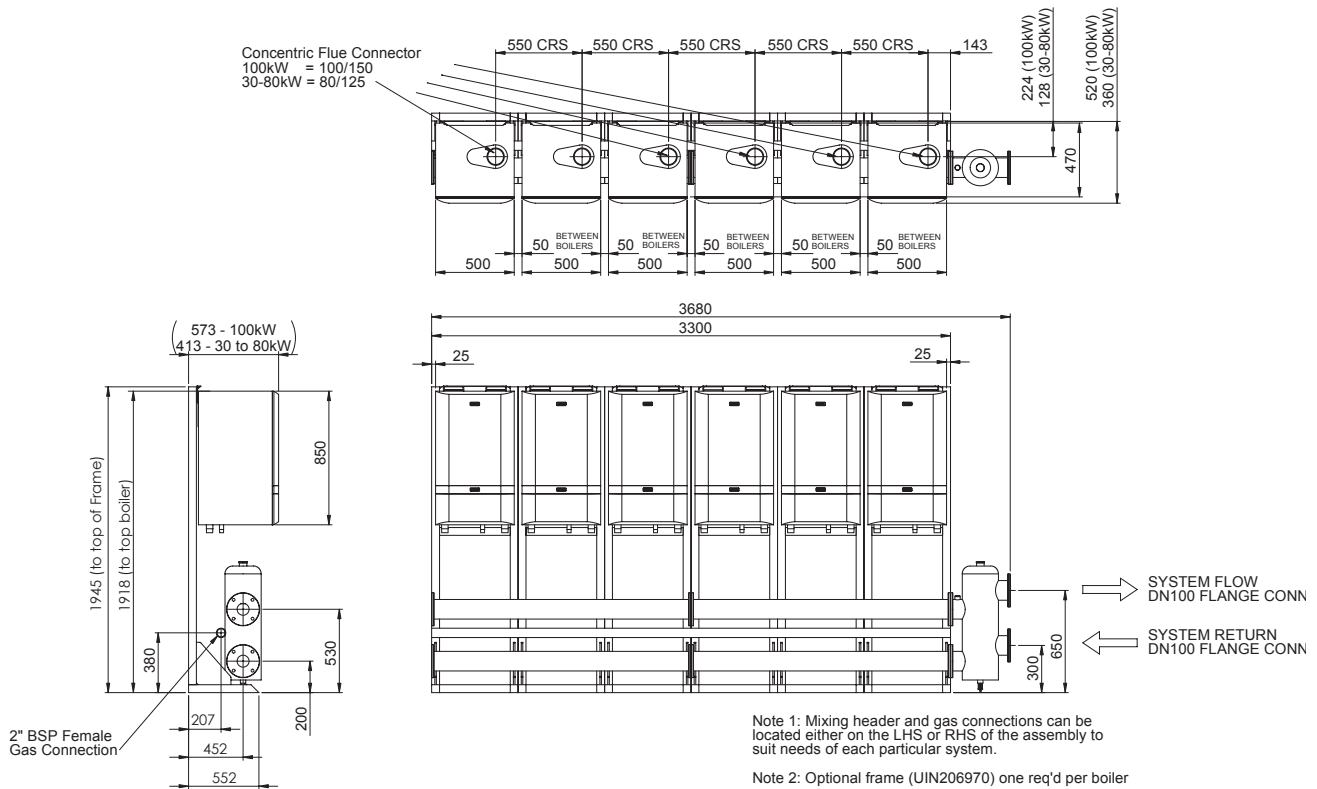

ALL DIMENSIONS ARE IN mm

Inline frame & header Kit 30-100kW UIN209806 with six Evomax 30-100kW boilers mounted onto optional frames

4.3 BACK TO BACK FRAME KIT CONFIGURATION-

4.3.1 INSTALLATION DRAWING WITH 2 – 30-100 BOILERS (BACK TO BACK)

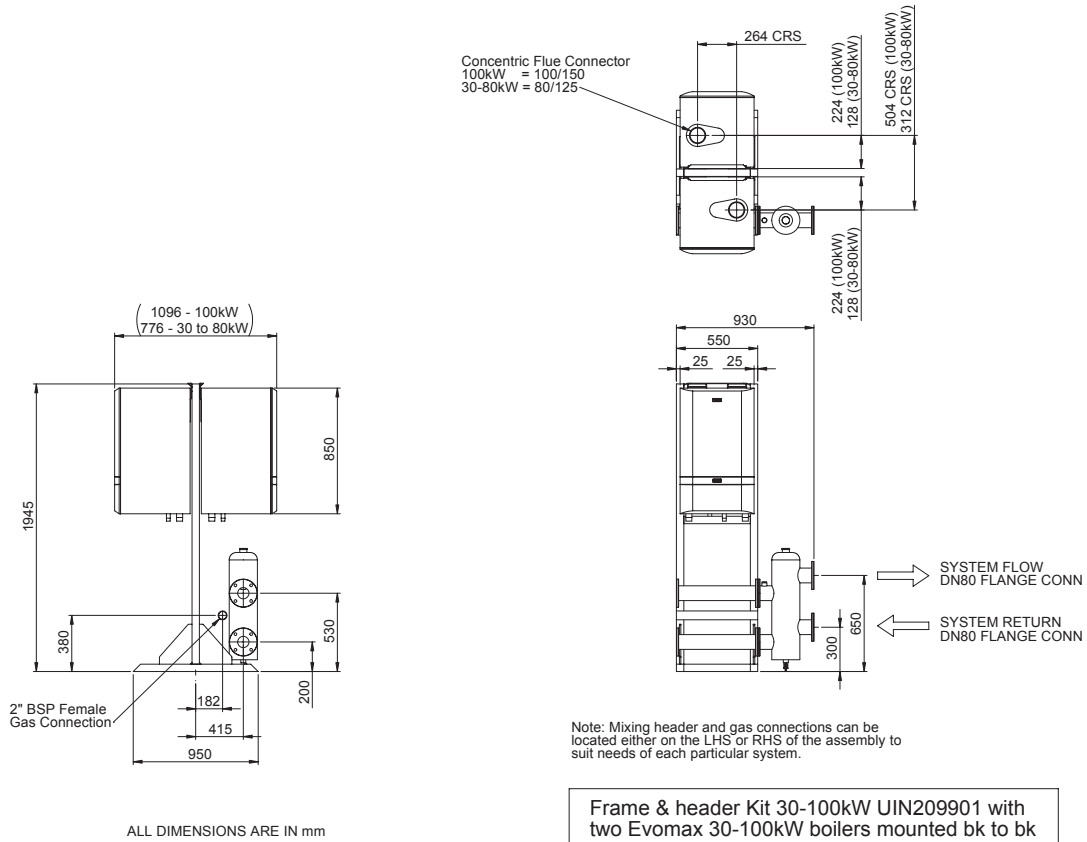

4.3.2 INSTALLATION DRAWING WITH 2 – 120/150 BOILERS (BACK TO BACK)

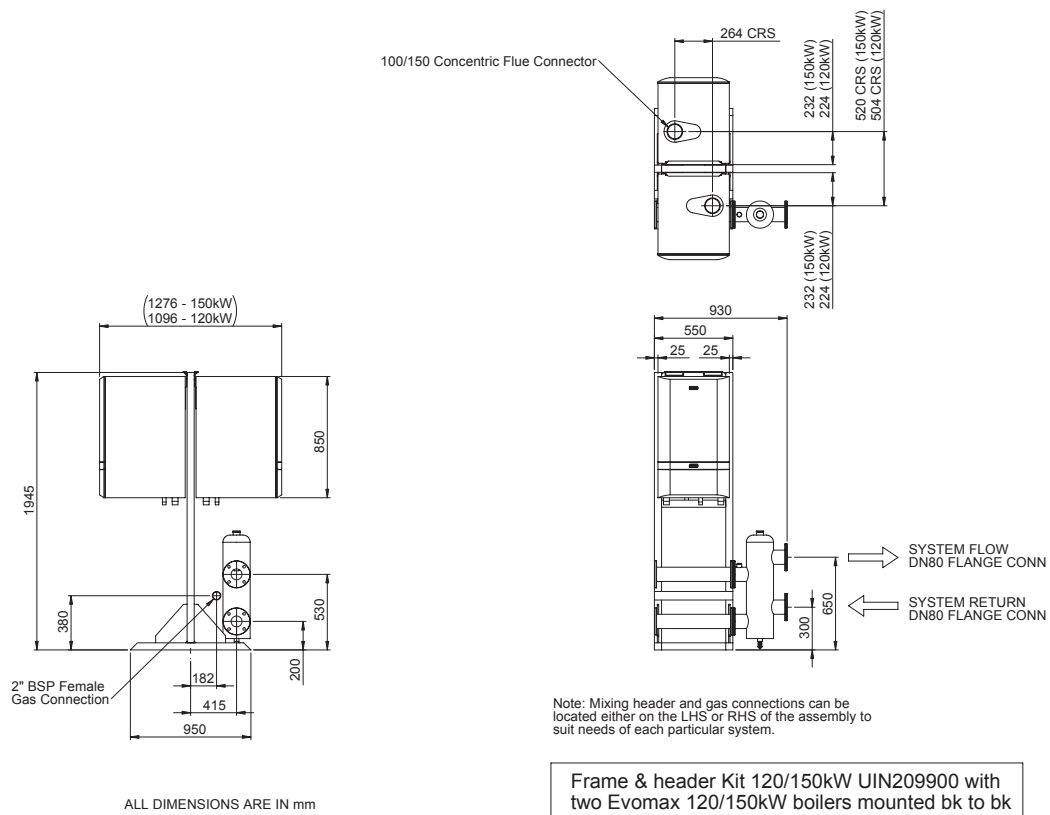

4.3.3 INSTALLATION DRAWING WITH 3 – 30-100 BOILERS (BACK TO BACK)

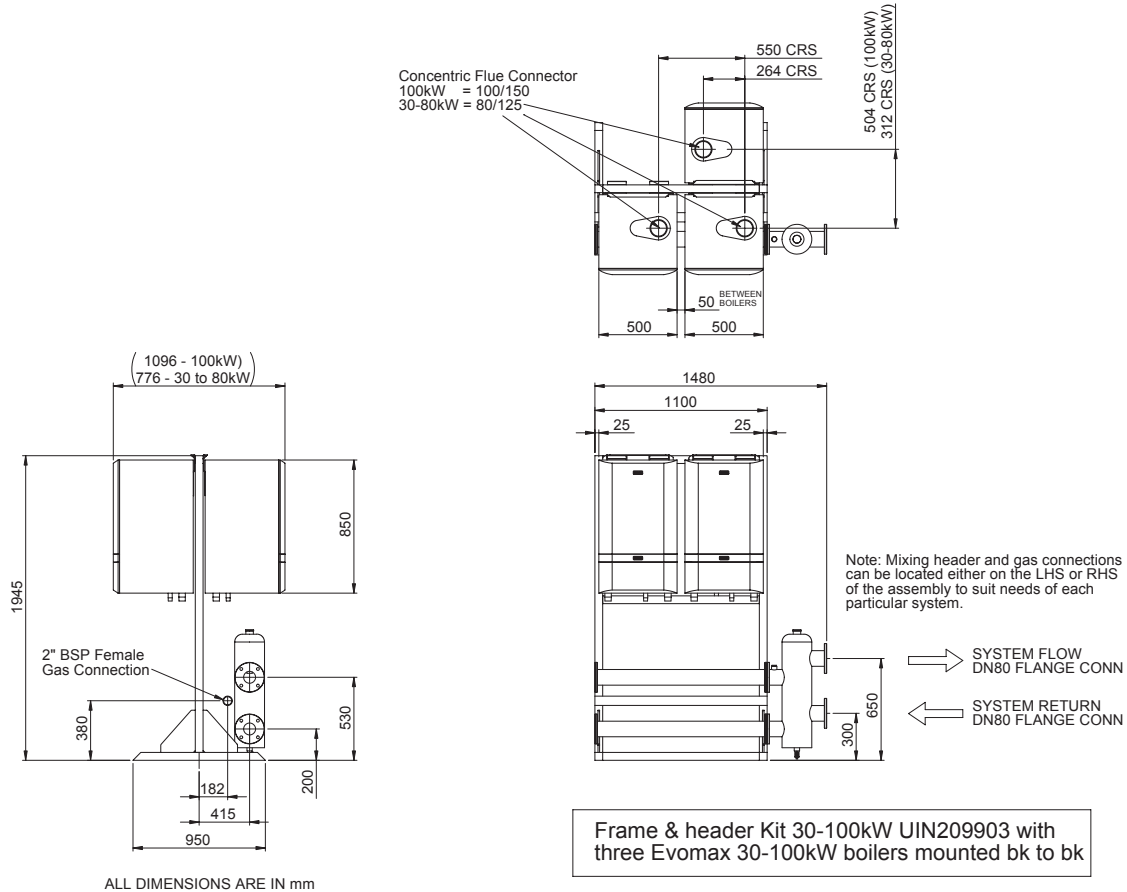

4.3.4 INSTALLATION DRAWING WITH 3 – 120/150 BOILERS (BACK TO BACK)

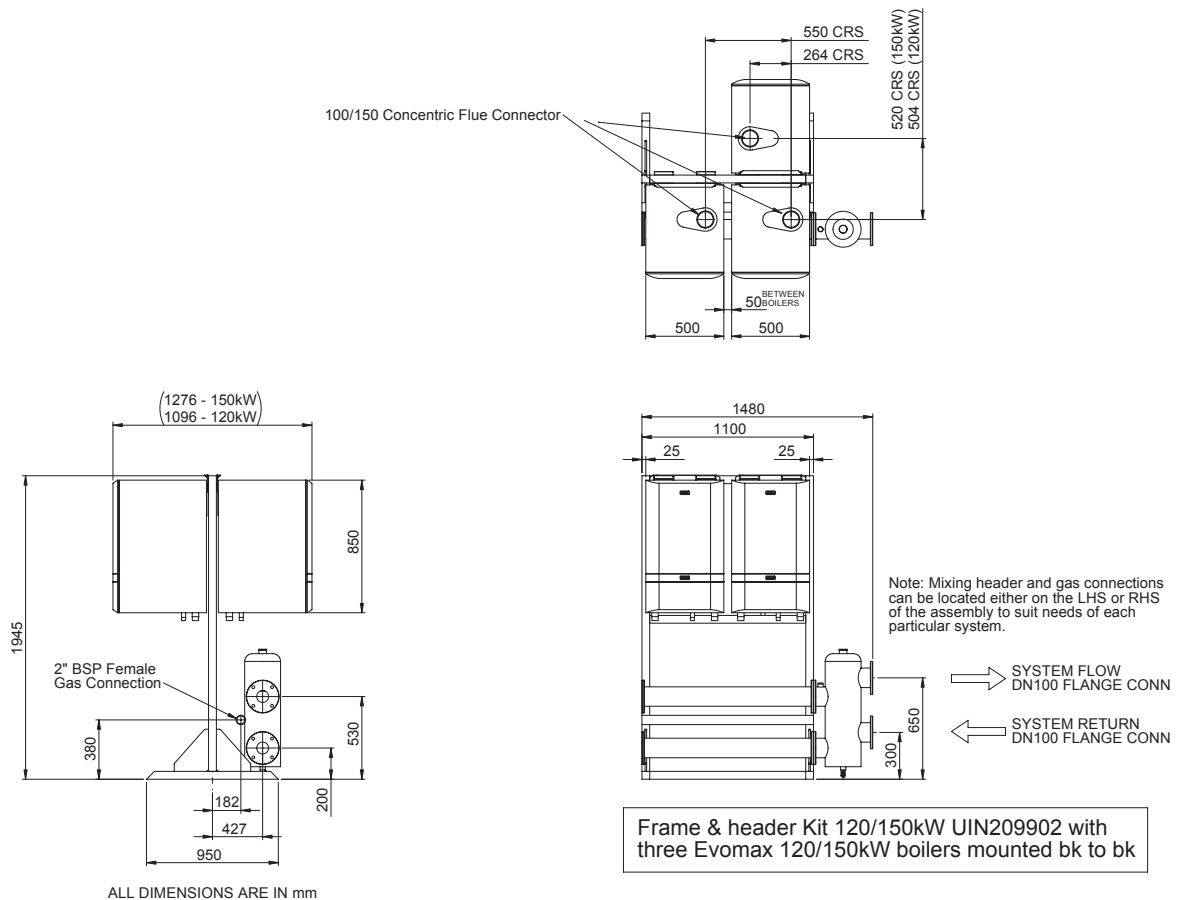

4.3.5 INSTALLATION DRAWING WITH 4 – 30-100 BOILERS (BACK TO BACK)

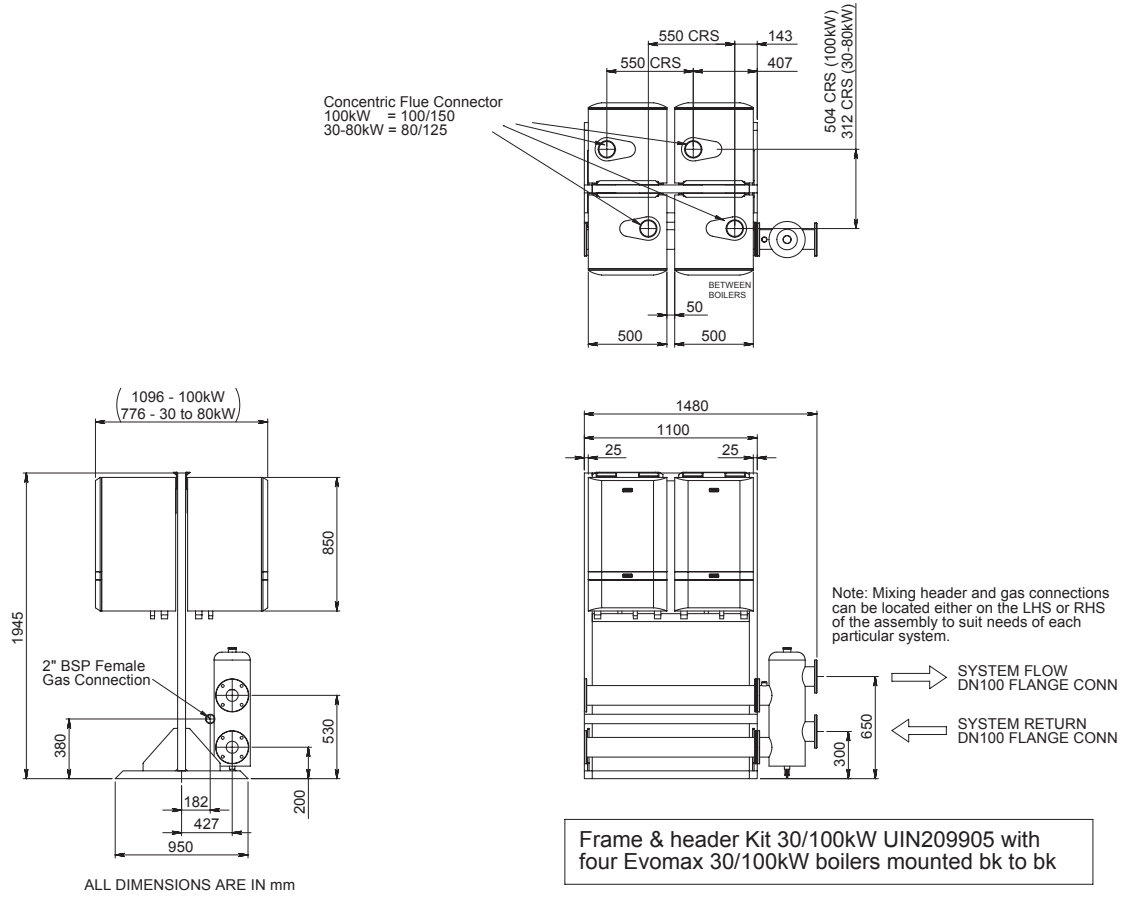

4.3.6 INSTALLATION DRAWING WITH 4 – 120/150 BOILERS (BACK TO BACK)

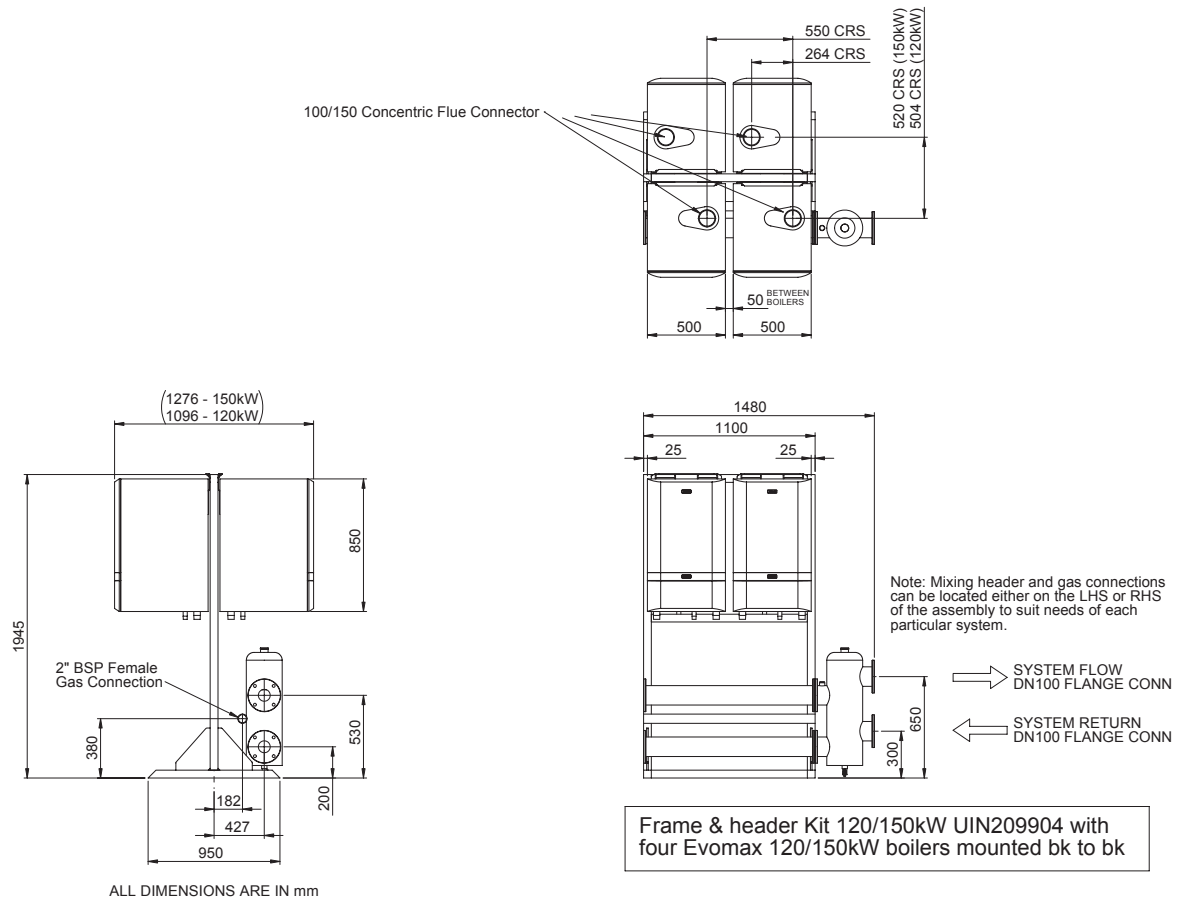

4.3.7 INSTALLATION DRAWING WITH 5 – 30-100 BOILERS (BACK TO BACK)

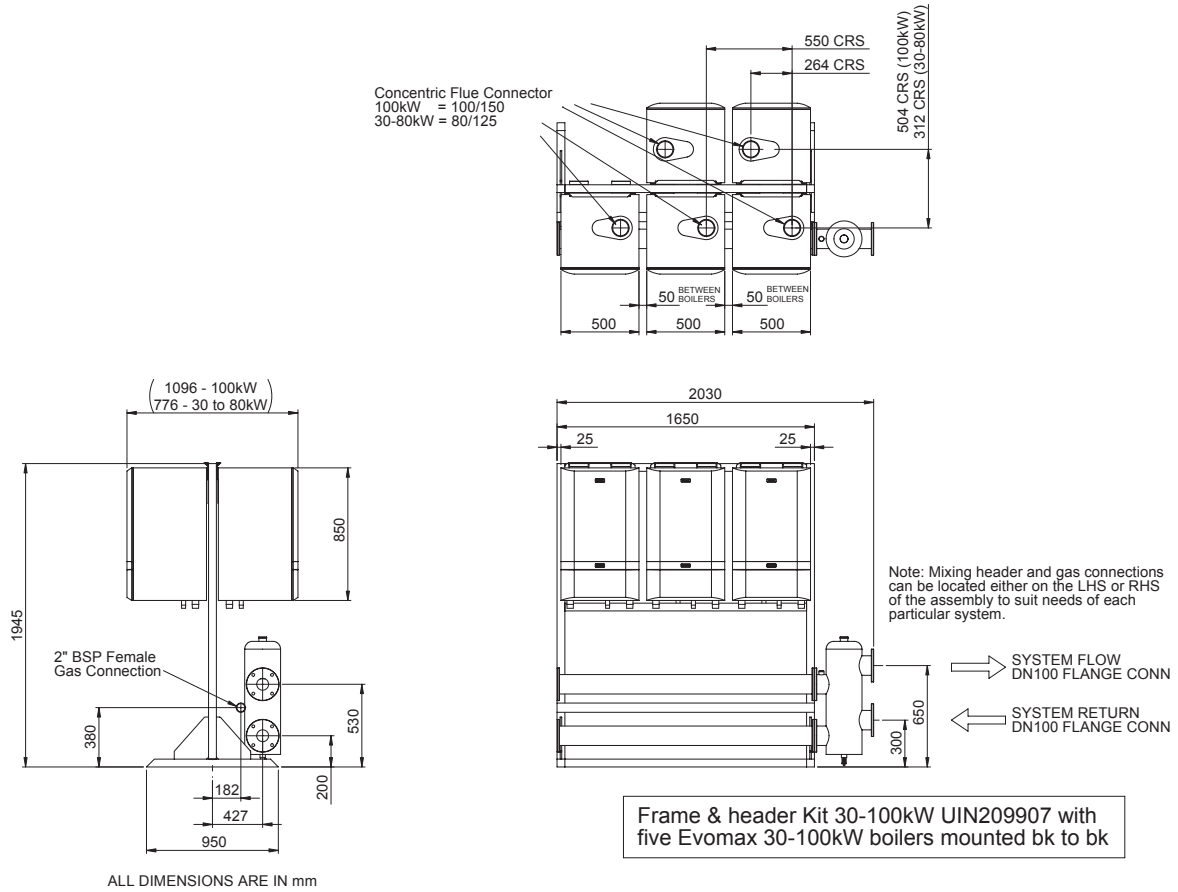

4.3.8 INSTALLATION DRAWING WITH 5 – 120 BOILERS (BACK TO BACK)

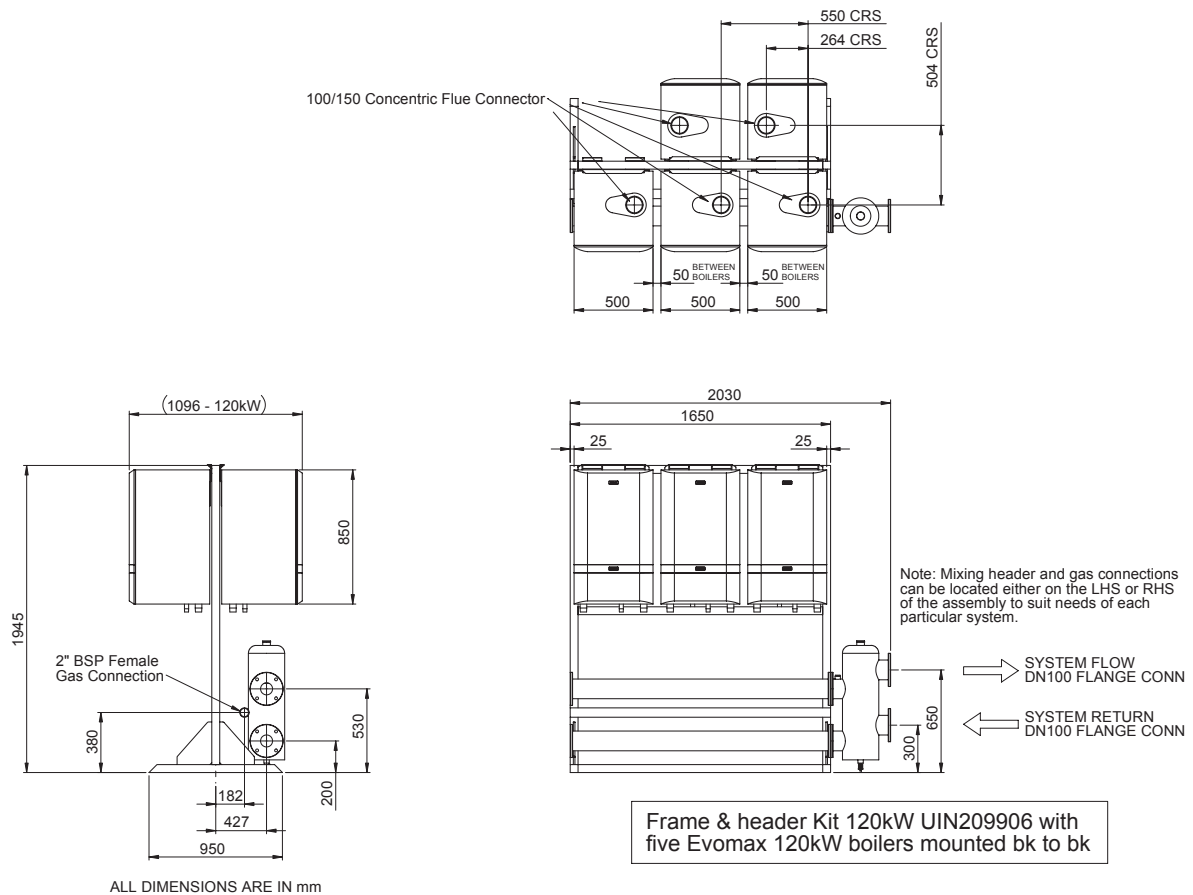

4.3.9 INSTALLATION DRAWING WITH 6 – 30-100 BOILERS (BACK TO BACK)

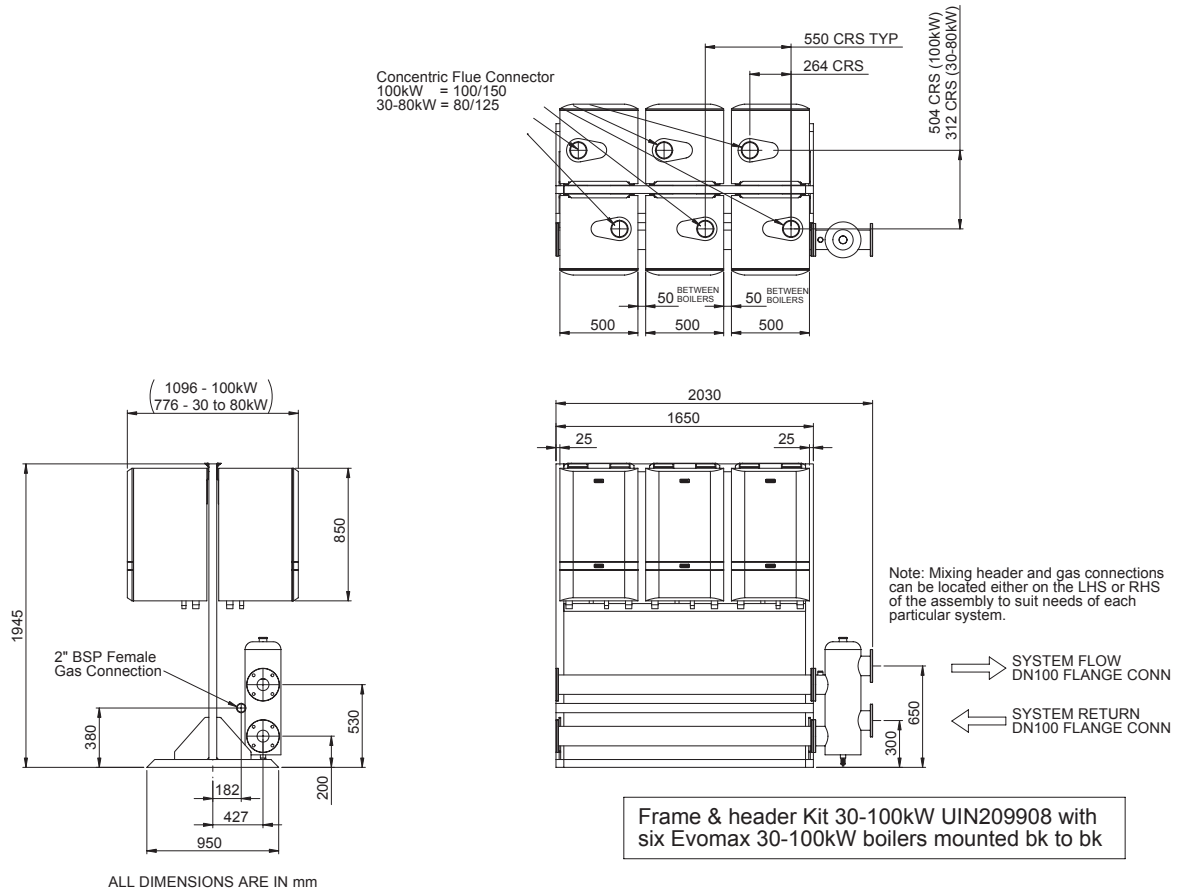

5 WALL MOUNTED INSTALLATION PROCEDURE

5.1 WALL MOUNTED SIDE BY SIDE OPTION

Ensure wall is capable of supporting the weight of boilers to be mounted. Note. boiler weights can be found in the boiler Installation Instructions.

1. Cut the sides off the cardboard wall mounting template/s (found in the boiler packaging) to create the 50mm side clearance required.
2. Mark the height on to the wall from the floor to the top of the boiler 1910mm.



3. Tape the template/s to the wall ensuring the 50mm side clearance per boiler requirement is adhered to.

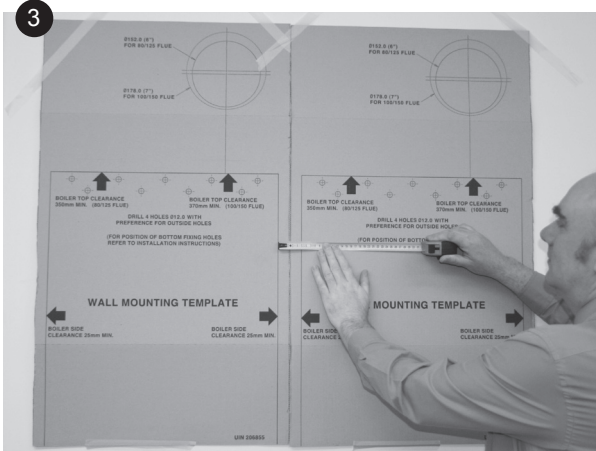

4. Drill the required holes in the wall to fit the wall mounting plate plugs. (See boiler Installation Instructions for details)

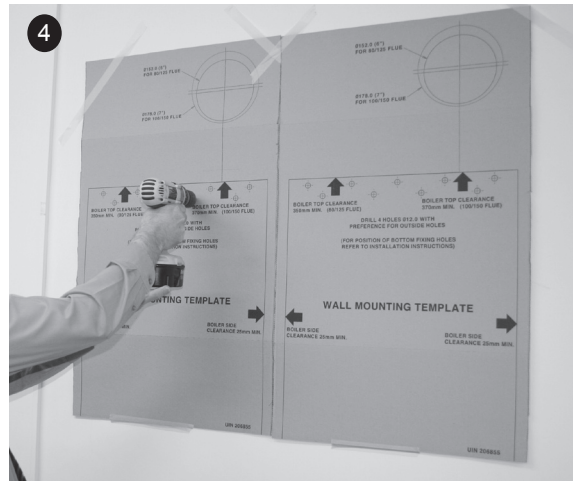

5. Screw the wall mounting plate(s) to the wall.



Floor Mounting: Align centre line of template to centre line of boiler and drill holes for headers.

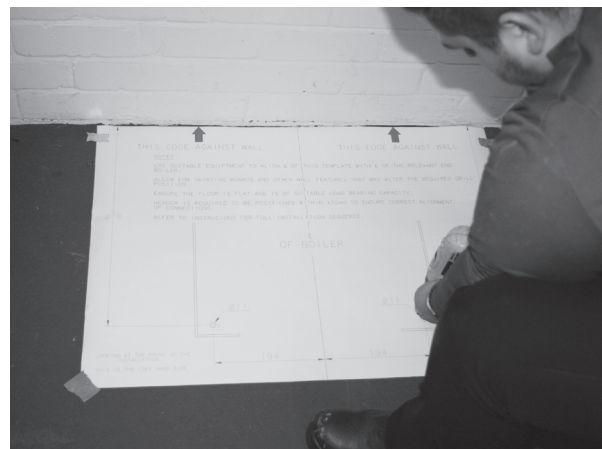

continued

5.1 WALL MOUNTED SIDE BY SIDE OPTION CONT'D.....

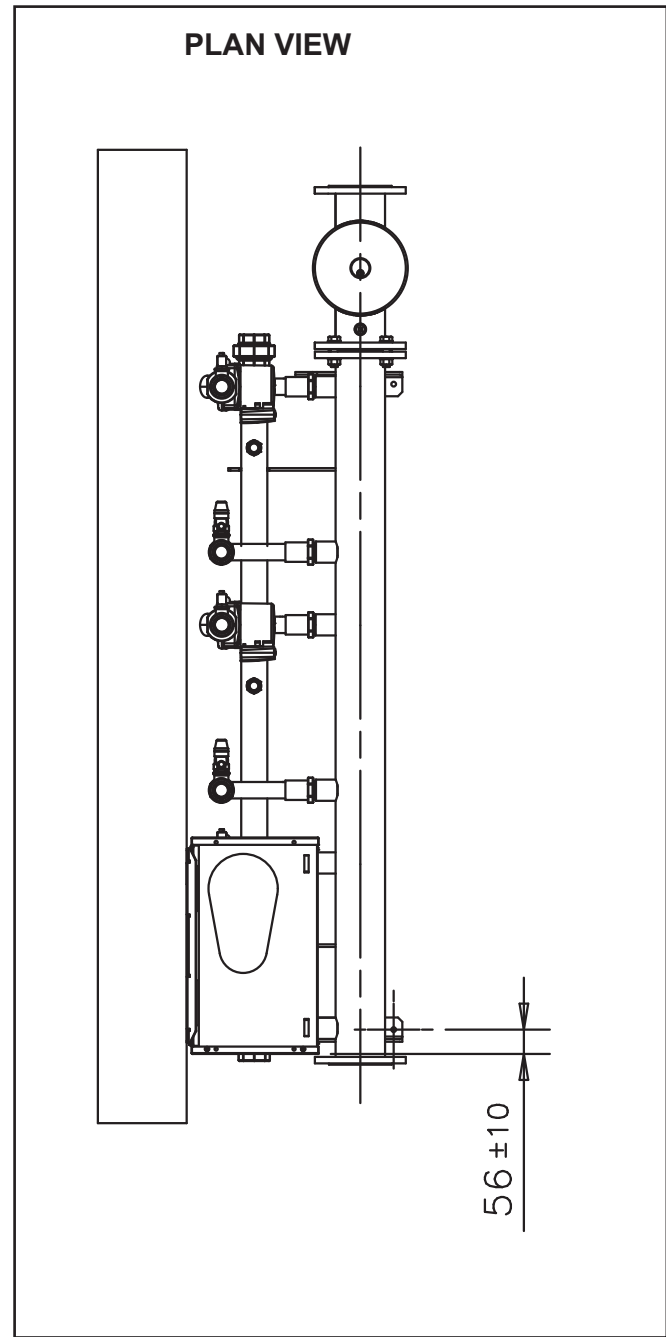
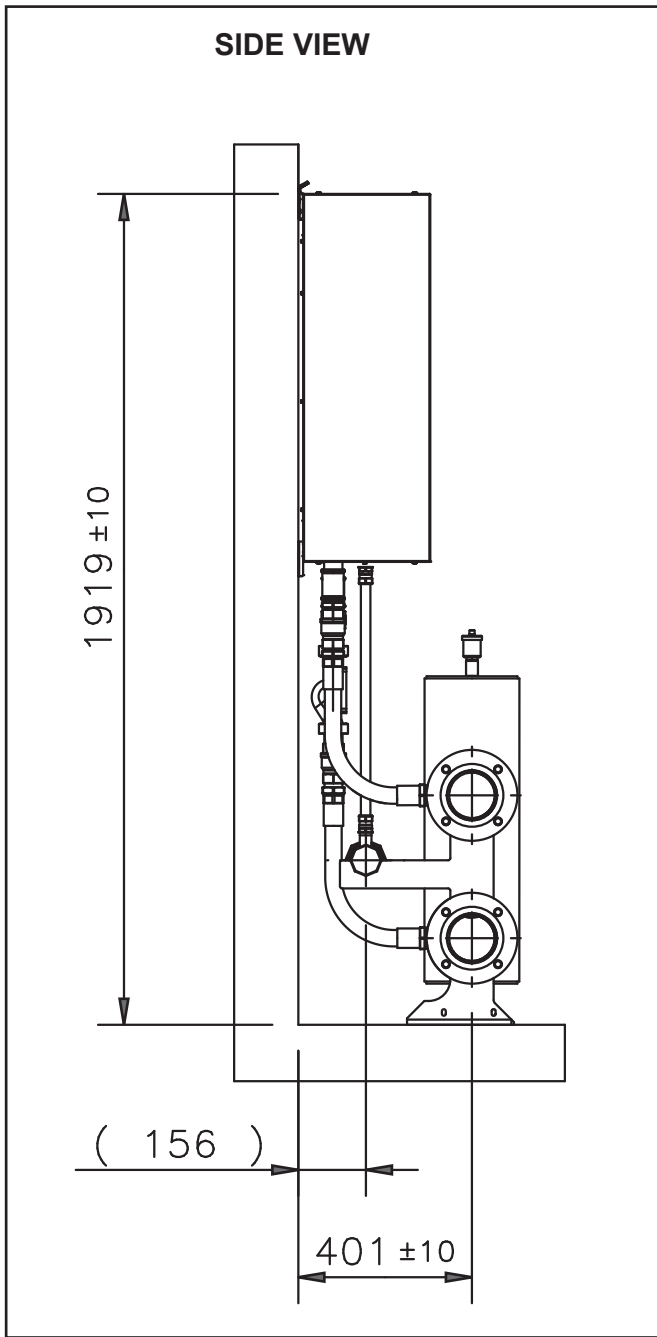

Careful consideration **MUST** be given to the installation tolerances. If these are not adhered to, hoses may become kinked or connections may not fit.

Bolt header to floor using template provided (front fixings only). Connect up hoses (see page 18)

6 FRAME KIT INSTALLATION PROCEDURE

6.1 SIDE BY SIDE FRAME KIT MOUNTING PROCEDURE

1. Place the frame kit sections in the required position and bolt them together at the top and bottom with the bolts, nuts and washers provided.

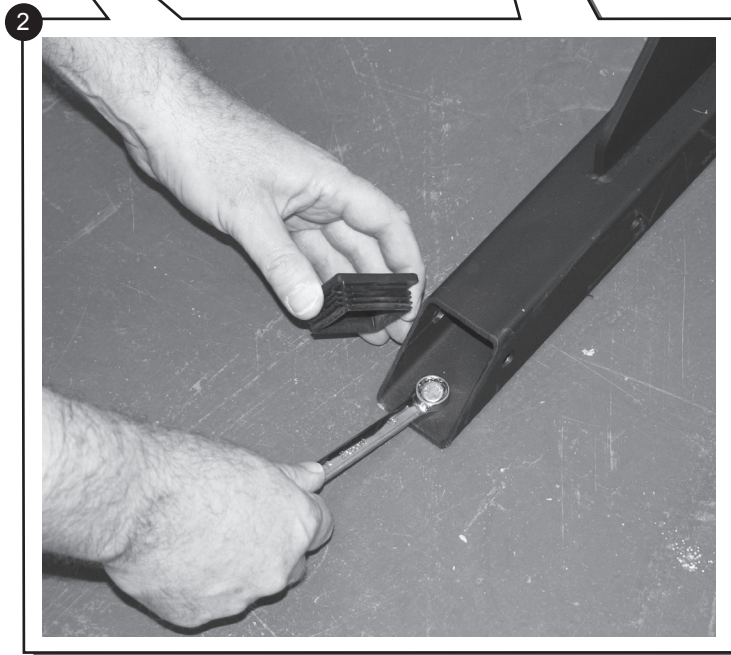
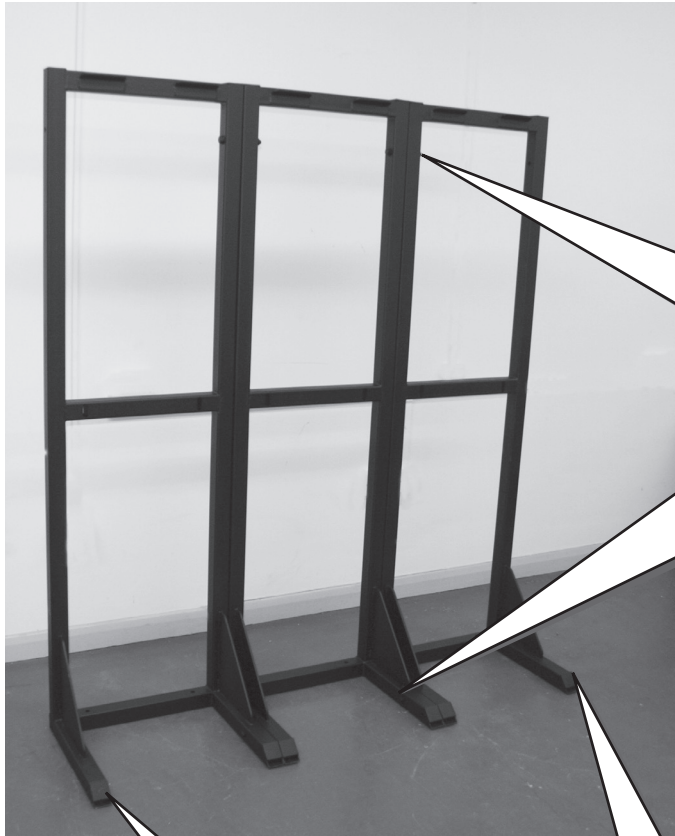

2. If additional stability is required remove the plastic foot covers and drill the floor in order to floor bolt the frame assembly to its required location. (Bolts not supplied in kit)

6.2 BOILER MOUNTING

1. As appropriate mount the boilers onto either the wall plates or the side by side frame kit.

1

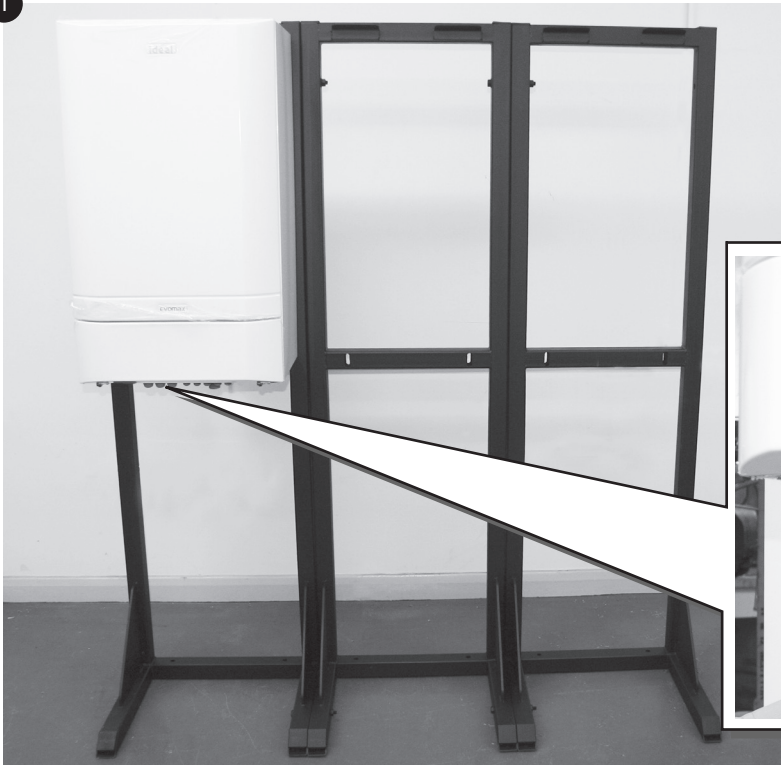

2. Ensure the boiler bottom fixing bracket is screwed to the frame or wall.

2

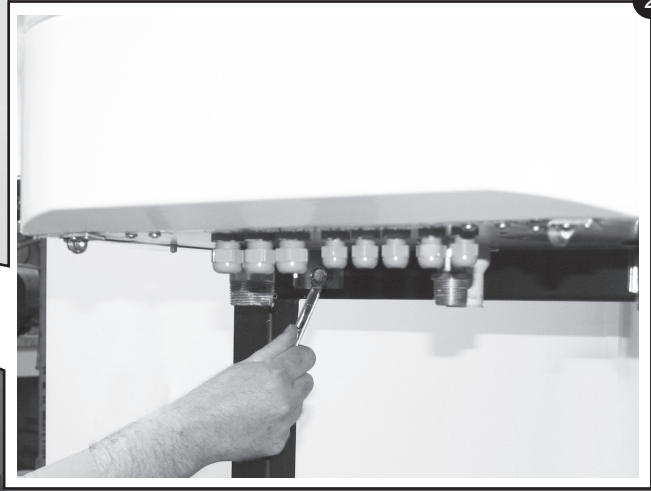

7 HEADER KIT ASSEMBLY

7.1 FITTING MIXING HEADER AND BLANKING FLANGES

1. Fit the mixing header and blanking flanges in the chosen positions.

Note. Mixing header can be located either LHS or RHS of the headers.

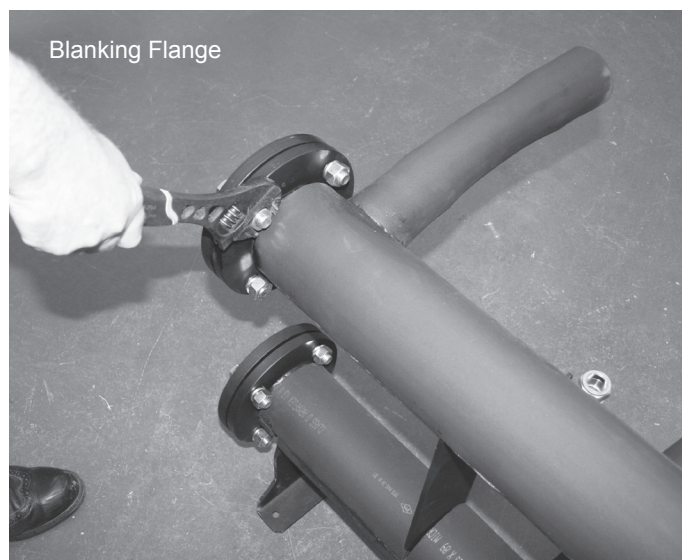

7.2 FITTING HEADER KIT ASSEMBLY

1. Slide the header kit assembly between the frame legs but do not screw the header kit to the frame at this stage.

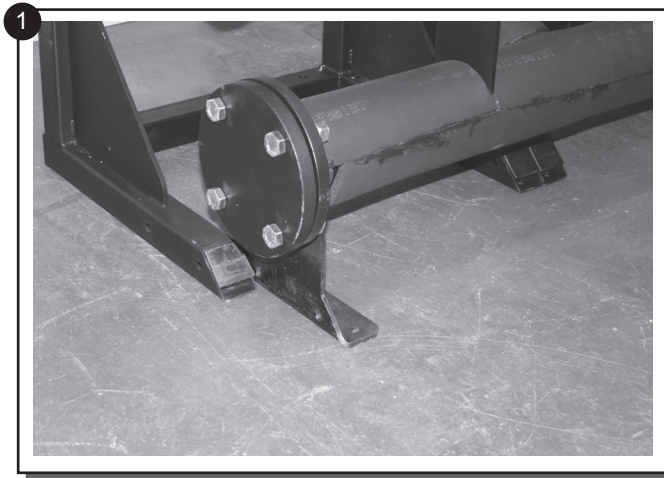

2. Screw the header legs to the frame feet with the bolts, nuts & washers provided.

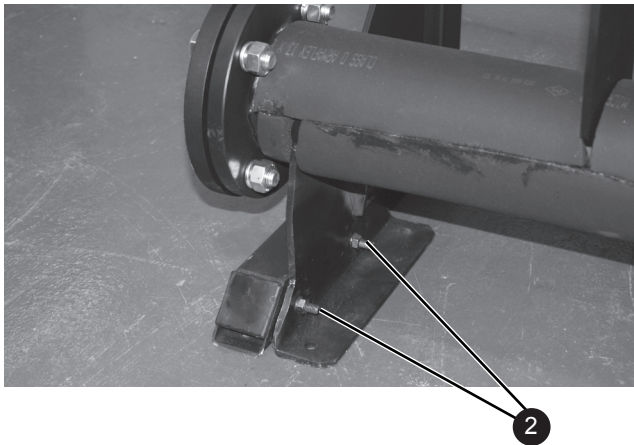

3. Connect the pump assembly to the boiler RH boiler return connection
4. Connect the isolating valve/pressure relief valve assembly to the boiler LH flow connection.

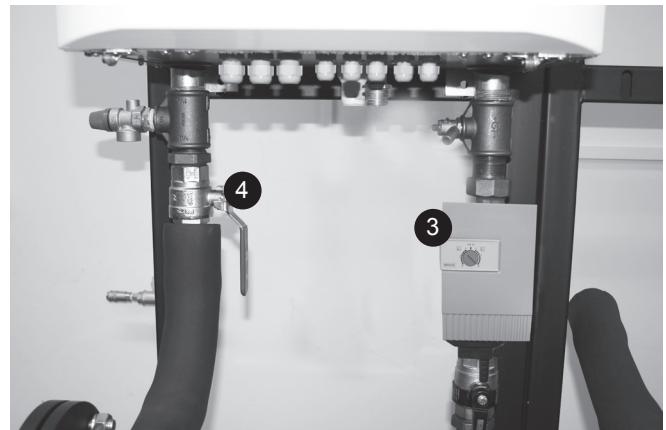

5. Fit the two flexible header connections to the boiler pump connection and the isolating valve connection ensuring the sealing washers are fitted.



7.3 FITTING GAS CONNECTION

1. Fit the gas isolation valve assembly to the boiler gas connection ensuring the sealing washer is fitted.

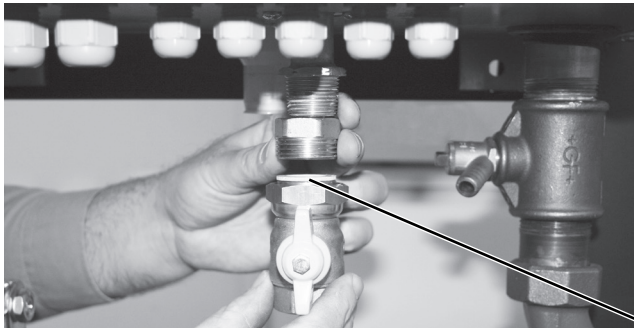

2. Fit the copper gas pipe provided in the connection kit to the isolating valve and the header gas connection using 22mm compression fittings provided.

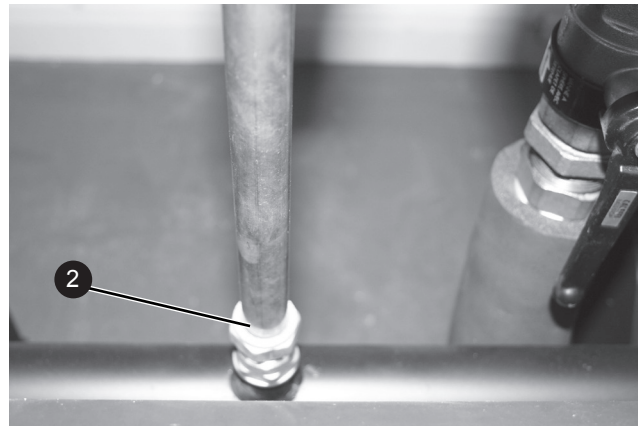
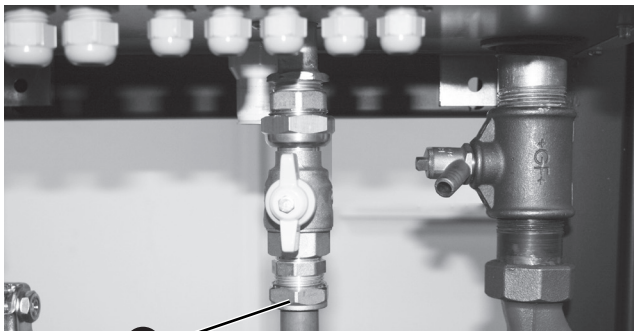

7.4 PRESSURE RELIEF VALVE CONNECTION

1. Ensure each boiler pressure relief connection is piped to safety.

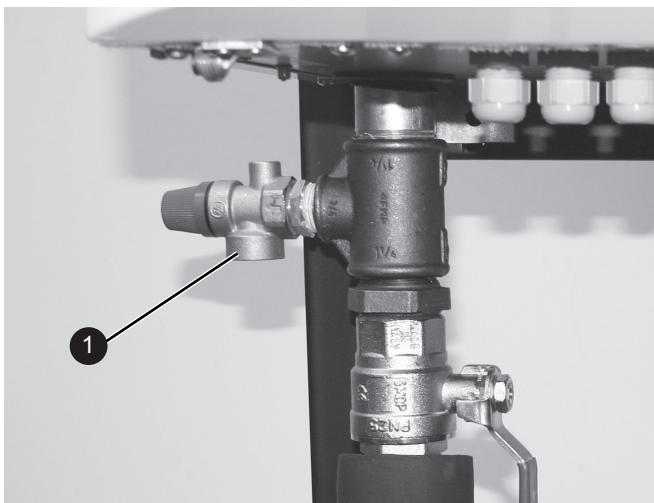

7.5 CONDENSATE SIPHON FITTING

1. Fit the condensate siphon to the boiler and pipe to drain following the recommendations contained in the boiler Installation instructions.

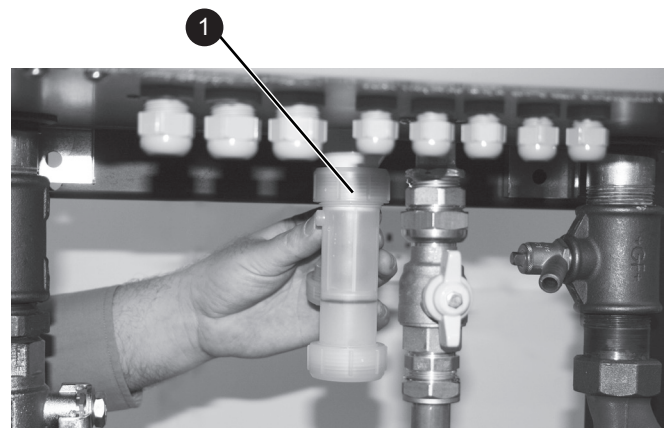

8 ELECTRICAL CONNECTIONS

1. Refer to the Installer Wiring Connection section in the boiler Installation Instructions for wiring details.
2. Ensure the boiler shunt pumps are wired to the boiler in order to ensure the boiler pump overrun facility is provided.

9 COMMISSIONING AND TESTING

1. Electrical and gas safety checks must be carried out on completion of installation as with individual boiler commissioning.
2. Pump setting adjustment. Follow instructions dependent on pump type as set out below;

If pump supplied is marked '**GRUNDFOS**' then adjust speed setting to No. 3, as shown below.



If pump supplied is marked '**WILO**' then adjust red control potentiometer to full clockwise position, as shown below.



Technical Training

The Ideal Boilers Technical Training Centre offers a series of first class training courses for domestic, commercial and industrial heating installers, engineers and system specifiers. For details of courses please ring: 01482 498 432

Ideal is a trademark of Ideal Boilers.

Registered Office

Ideal Boilers Limited National Avenue, Hull, HU5 4JB.

Telephone: 01482 492 251 Fax: 01482 448 858

Registered in England no. 322137.

Ideal Boilers Limited pursues a policy of continuing improvement in the design and performance of its products. The right is therefore reserved to vary specification without notice.



Ideal Installer/Technical Helpline: 01482 498 376

www.idealcommercialboilers.com